

# ***SCORPION HORIZONTAL PACKING MACHINE***



***SCORPION MACHINERY CATALOGUE***



# 5 SERIES OF ECCOPAC SCORPION HORIZONTAL PACKING MACHINERY

## DS/SCORPION DOYPACK SERIES

**DS/SCORPION** series is designed for Doypack kind packing need. It can make standard doypack kind pouches, as well as with special additional functions like zipper, hanging hole, spout or special shapes. It also has big size doypack kind series and duplex doypack kind series, which can meet packing requirement of big volume and high speed.

La serie **DS/SCORPION** está diseñada para las necesidades de envasado en bolsas tipo doypack. Puede fabricar bolsas tipo doypack estándar y, dependiendo de las funciones adicionales especiales, puede fabricar bolsas tipo doypack con cremallera zipper, orificio para colgar, boquilla o formas especiales. También contamos con las series tipo doypack de gran tamaño y serie tipo duplex, que pueden cumplir con los requisitos de embalaje de gran volumen y alta velocidad respectivamente.

- **Simplex Series:** DS/SCORPION-140S, DS/SCORPION-140SZ, DS/SCORPION-140SC, DS/SCORPION-140(B), DS/SCORPION-180S, DS/SCORPION-180SZ, DS/SCORPION-180SC, DS/SCORPION-180SXC.
- **Big Size Series:** DS/SCORPION-240S, DS/SCORPION-240SZ, DS/SCORPION-240SXC.
- **Duplex Series:** DS/SCORPION-180DS, DS/SCORPION-180DS(B), DS/SCORPION-280DS, DS/SCORPION-280DSZ, DS/SCORPION-280DSC, DS/SCORPION-280DSXC, DS/SCORPION-360DS, DS/SCORPION-360DSZ.

## HS/SCORPION HIGH SPEED SERIES

**HS/SCORPION** series is designed to meet high speed packing need of small bags. With triplex series maximum speed is 320 bags per minute.

La serie **HS/SCORPION** está diseñada para satisfacer las necesidades de envasado de alta velocidad de bolsas pequeñas. Con la serie triplex, la velocidad máxima es de 320 bolsas por minuto.

- **QUADRIPLEX Series:** HS/SCORPION-360Q, HS/SCORPION-360DT.

## V/SCORPION VACUUM PACKING SERIES

**V/SCORPION** series is designed for product vacuum packaging. Standard packaging machine is attached with chamber type vacuum sealing unit to reach the vacuum packaging need.

La serie **V/SCORPION** está diseñada para el envasado de productos al vacío. La máquina de envasado estándar se adjunta con una unidad de cámara de sellado al vacío para poder realizar bolsas de vacío bien confeccionadas y con alta calidad de sellado.

- **VB CHAMBER TYPE:** VBS/SCORPION-180, VBSG/SCORPION-180, VBSG/SCORPION-180D.

## SG/SCORPION PRE-MADE POUCH SERIE

**SG/SCORPION** series is designed for pre-made pouch machine. It can do automatic filling, sealing of doypack kind pouches, flat pouch and pouches with zipper, hanging hole or special shape. It also has big size series and duplex series, which can meet packaging requirement of big volume and high speed.

La serie de máquinas **SG/SCORPION** está diseñada para envasar en bolsas prefabricadas. Puede realizar el llenado automático, sellado de bolsas tipo doypack, bolsas planas y bolsas con cremallera, orificio para colgar o forma especial. También tiene series de envasado en bolsas de gran tamaño y series duplex, que pueden cumplir con los requisitos de envasado de gran volumen y alta velocidad.

- **SMALL SIZE SERIES:** SG/SCORPION-180, SG/SCORPION-180Z, SG/SCORPION-180C, SG/SCORPION-180D, SG/SCORPION-180XC, SG/SCORPION-210, SG/SCORPION-210Z.
- **BIG SIZE SERIES:** SG/SCORPION-240, SG/SCORPION-240Z, SG/SCORPION-280, SG/SCORPION-280Z, SG/SCORPION-280XC.
- **DUPLEX SERIES:** SG/SCORPION-360D, SG/SCORPION-360DZ, SG/SCORPION-360DC.

## S/SCORPION STANDARD MACHINE

**S/SCORPION** series is designed for form standard flat pouch and small doypack. It can form three-side, four-side seal and twin-link bag function. It can produce different bags with special functions on flat pouch with choices of zipper, hanging hole, spout and special shape. It can also has big size series and duplex series, which can meet packing requirement of big volume and high speed.

La serie **S/SCORPION** está diseñada para formar bolsa plana estándar y bolsa tipo doypack pequeña. Puede formar bolsas tipo sobre de sello de tres costuras, cuatro costuras y una función de bolsa doble. Puede producir diferentes bolsas con funciones especiales en bolsas planas con opciones de cremallera zipper, orificio para colgar, pico y forma especial. También puede tener series de gran tamaño y series dúplex, que pueden cumplir con los requisitos de embalaje de gran volumen y alta velocidad.

- **SIMPLEX SERIES:** S/SCORPION-110, S/SCORPION-110T, S/SCORPION-130, S/SCORPION-130B, S/SCORPION-180, S/SCORPION-180T, S/SCORPION-180Z, S/SCORPION-180C.
- **BIG SIZE SERIES:** S/SCORPION-240, S/SCORPION-240Z.
- **DUPLEX SERIES:** S/SCORPION-180D, S/SCORPION-180DC, S/SCORPION-240D, S/SCORPION-240DZ, S/SCORPION-240DC, S/SCORPION-240DZ, S/SCORPION-360D.



# ECCOPAC SCORPION

## DS/SCORPION DOYPACK SERIES

### SMALL STAND UP POUCH.

SERIE DE ENVASADORAS DOYPACK DS/SCORPION  
BOLSAS AUTOESTABLE PEQUEÑAS



### SHAPED POUCH PUNCHING STRUCTURE

- Customized punching knife, personalized bag design. / *Cuchilla de troquelado personalizada, diseño de bolsa personalizado.*
- High precision and long life. / *Alta precisión y larga vida.*
- No burrs, high aesthetics. / *Sin rebabas, alta estética.*

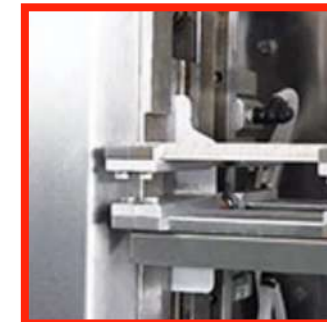

### INDEPENDENT COOLING DEVICE

- Cool before punching to ensure aesthetics. / *Enfriar antes de perforar para garantizar la buen acabado final.*
- With chiller, no burrs on the corners. / *Con enfriador, sin rebabas en las esquinas.*
- The upper seal is cooled to improve the appearance. / *El sello superior se enfría para mejorar la apariencia.*



### LINEAR GUIDE WALKING BEAM

- Higher operating speed. / *Mayor velocidad de funcionamiento.*
- Longer service life. / *Mayor vida útil.*
- More convenient maintenance. / *Mantenimiento más conveniente.*



### DS/SCORPION-140SC PRODUCTION FLOW:

1.Film Unwind. 2.Bottom Hole Punching. 3.Bag Forming. 4.Film Guide. 5.Bottom Seal. 6.Vertical Seal I. 7.Vertical Seal II. 8.Photocell. 9.Servo Advance. 10.Cutting. 11.Pouch Catching I. 12.Pouch Catching II. 13. Pouch Opening. 14.Air Flushing. 15.Filling I. 16.Filling II. 17.Spout Inserting. 18.Vibrator. 19.Top Seal I. 20.Top Seal II. 21.Finished Product. 22.Outlet /

1.Debobinador. 2.Perforador de base. 3.Formador de bolsa. 4.Guía de film. 5.Sello inferior. 6.Sello vertical I. 7.Sello vertical II. 8.Sensor de fotocélula. 9.Tracción de bobina por servomotor. 10.Cuchilla de corte. 11.Sugetador de bolsa I. 12.Sugetador de bolsa II. 13.Abertura de pouch. 14.Soplado de bolsa. 15.Dosificación I. 16.Dosificación II. 17.Colocación de Spout. 18.Dosificador de spout pot vibración. 19.Sello superior I. 20.Sello superiorII. 21.Producto final. 22.Banda de salida.

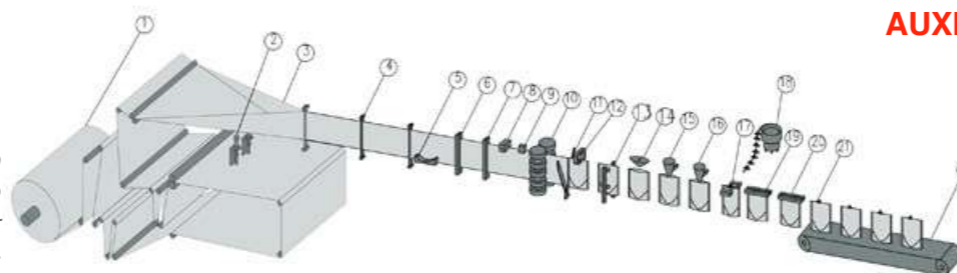

### AUXILIARY BAG OPENING INDEPENDENT BAG STRETCHING



Model / modelo	Pouch Size / Dimensiones del pouch	Filling Capacity / Volumen de llenado	Packaging Capacity / Capacidad de Envasado	Power / Potencia	Air Consumption / Consumo neumático	Machine Dimensions / Dimensiones de la máquina	Weight / Peso	Function / Función
DS/SCORPION-140S	Min: 60x90mm Max: 140x200mm	300ml	40-60ppm	6.5kw	200 NL/min	L: 4480mm W: 970mm H: 1400mm	1600Kg	Flat Pouch, Auto Stand Pouch (Doypack) / Sobre plano, Pouch auto estable (Doypack)
DS/SCORPION-140SZ	Min: 60x90mm Max: 140x200mm	300ml	40-60ppm	8kw	200 NL/min	L: 4780mm W: 970mm H: 1400mm	1800Kg	Flat Pouch, Auto Stand Pouch (Doypack) / Sobre plano, Pouch auto estable (Doypack)
DS/SCORPION-140SC	Min: 60x90mm Max: 140x200mm	300ml	40-60ppm	7.4kw	250NL/min	L: 4480mm W: 970mm H:1400mm	1600Kg	Flat Pouch, Auto Stand Pouch (Doypack), Top Spout / Sobre plano, Pouch auto estable (Doypack), Boquilla superior
DS/SCORPION-140S(B)	Min: 60x90mm Max: 140x200mm	300ml	40-60ppm	6.5kw	500 NL/min	L: 4480mm W: 970mm H: 1400mm	1600Kg	Flat Pouch, Auto Stand Pouch (Doypack), Special Pack / Sobre plano, Pouch auto estable (Doypack), Envases especiales.



# ECCOPAC SCORPION

## DS/SCORPION DOYPACK SERIES

### SMALL STAND UP POUCH.

SERIE DE ENVASADORAS DOYPACK **DS/SCORPION**  
BOLSAS AUTOESTABLES PEQUEÑAS



#### DS/SCORPION-180DS PRODUCTION FLOW:

1.Film Unwind 2.Bottom Hole Punching 3.Bag Forming 4.Film Guide 5.Bottom Seal 6.Vertical Seal I 7.Vertical Seal II 8.Tear Notch 9.Photocell 10.Servo Advance 11.Cutting 12.Pouch Catching 13. Pouch Opening 14.Air Flushing 15.Filling I 16.Filling II 17.Top Seal I 18.Top Seal II 19.Finished Product 20.Outlet /  
1.Debobinador. 2.Perforador de base. 3.Formador de bolsa. 4.Guía de film. 5.Sello inferior. 6.Sello vertical I. 7.Sello vertical II. 8.Mueza abre fácil. 9.Sensor de fotocélula. 10.Tracción de avance por servo. 11.Cuchilla. 12.Sijetador de pouch. 13.Abertura de pouch. 14.Soplado de bolsa. 15.Dosificación I. 16.Dosificación II. 17.Sello superior I. 18.Sello superiorII. 19.Producto final. 20.Banda de salida.

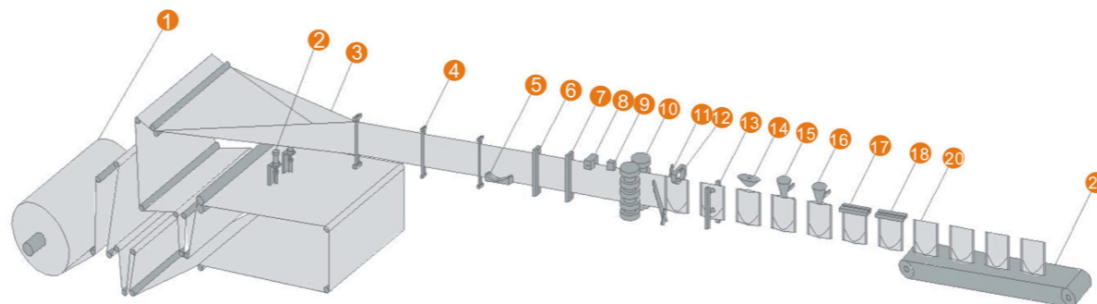

#### SHAPED POUCH PUNCHING STRUCTURE

- Customized punching knife, personalized bag design. / *Cuchilla de troquelado personalizada, diseño de bolsa personalizado.*
- High precision and long life. / *Alta precisión y larga vida.*
- No burrs, high aesthetics. / *Sin rebabas, alta estética.*



#### INDEPENDENT COOLING DEVICE

- Cool before punching to ensure aesthetics. / *Enfriar antes de perforar para garantizar la buen acabado final.*
- With chiller, no burrs on the corners. / *Con enfriador, sin rebabas en las esquinas.*
- Independent top cool seal improve the appearance. / *El sello superior se enfría para mejorar la apariencia.*



#### FULL SERVO DRIVING

- Higher operating speed. / *Mayor velocidad de funcionamiento.*
- Longer service life. / *Mayor vida útil.*
- More convenient maintenance. / *Mantenimiento más conveniente.*



#### DUPLEX OUTLET

- Shorten the filling time and increase the packing speed. / *Reduce el tiempo de llenado y aumenta la velocidad de envasado.*



Model / modelo	Pouch Size / Dimensiones del pouch	Filling Capacity / Volumen de llenado	Packaging Capacity / Capacidad de Envasado	Power / Potencia	Air Consumption / Consumo neumático	Machine Dimensions / Dimensiones de la máquina	Weight / Peso	Function / Función
DS/SCORPION-180DS	Min: 60x100mm Max: 90x180mm	150ml	80-120ppm	6.8kw	300 NL/min	L: 5330mm W: 970mm H: 1400mm	2000Kg	Flat Pouch, Auto Stand Pouch (Doypack) / Sobre plano, Pouch auto estable (Doypack)
DS/SCORPION-180DS(B)	Min: 60x100mm Max: 90x180mm	150ml	80-120ppm	8.3kw	600 NL/min	L: 5630mm W: 970mm H: 1400mm	2200Kg	Flat Pouch, Auto Stand Pouch (Doypack), Special Pack / Sobre plano, Pouch auto estable (Doypack), Envases especiales.



**eccopac**

# ECCOPAC SCORPION

## DS/SCORPION DOYPACK SERIES

STAND UP POUCHES, HANGING HOLE, SPECIAL SHAPE, ZIPPER OR SPOUT

SERIE DE ENVASADORAS DOYPACK DS/SCORPION

BOLSA AUTO ESTABLE, ASA SUJETADORA, FORMA ESPECIAL, ZIPPER Y SPOUT



### DS/SCORPION-180DS PRODUCTION FLOW:

1.Film Unwind 2.Bottom Hole Pouching 3.Bag Forming 4.Film Guide 5.Bottom Seal 6.Vertical Seal I 7.Vertical Seal II 8.Photocell 9.Servo Advance 10.Cutting 11.Pouch Catching I 12.Pouch Catching II 13.Slant Opening Cutting 14.First Pouch Opening 15.Vibrator 16.Spout Inserting 17.Spout Seal 18.Second Pouch Opening 19.Air Flushing 20.Filling I 21.Filling II 22.Pouch Stretching 23.Top Seal I 24.Top Seal II 25.Finished Product 26.Outlet / 1.Debobinador. 2.Perforador de base. 3.Formador de bolsa. 4.Guía de film. 5.Sello inferior. 6.Sello vertical I. 7.Sello vertical II. 8.Sensor de fotocélula. 9.Tracción de avance por servo. 10.Cuchilla. 11.Sijetador de pouch. 13.Corte de esquina. 14.Abertura de pouch. 15.Vibrador dosificador de Spout. 16.Colocación de Spout. 17.Sello de Spout. 18 Segundo abridor de bolsa. 19.Soplado de bolsa. 20.Dosificación I. 21.Dosificación II. 22.Cerrado de pouch. 23.Sello superior I. 24.Sello superiorII. 25.Producto final. 26.Banda de salida.

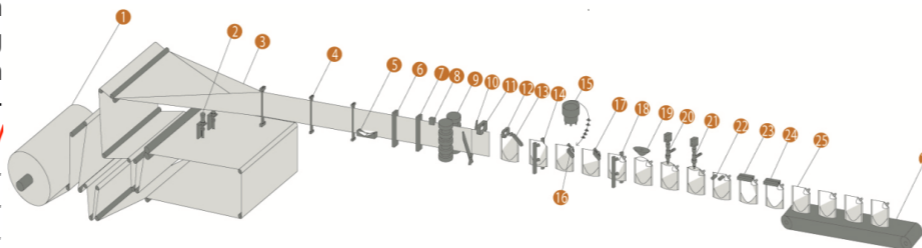

### SHAPED POUCH PUNCHING STRUCTURE

- Customized punching knife, personalized bag design. / Cuchilla de troquelado personalizada, diseño de bolsa personalizado.
- High precision and long life. / Alta precisión y larga vida.
- No burrs, high aesthetics. / Sin rebabas, alta estética.



### INDEPENDENT COOLING DEVICE

- Cool before punching to ensure aesthetics. / Enfría antes de perforar para garantizar la buen acabado final.
- With chiller, no burrs on the corners. / Con enfriador, sin rebabas en las esquinas.
- Independent top cool seal improve the appearance. / El sello superior se enfría para mejorar la apariencia.



### FULL SERVO DRIVING

- Higher operating speed. / Mayor velocidad de funcionamiento.
- Longer service life. / Mayor vida útil.
- More convenient maintenance. / Mantenimiento más conveniente.



### DUPLEX OUTLET

- Shorten the filling time and increase the packing speed. / Reduce el tiempo de llenado y aumenta la velocidad de envasado.



Model / modelo	Pouch Size / Dimensiones del pouch	Filling Capacity / Volumen de llenado	Packaging Capacity / Capacidad de Envasado	Power / Potencia	Air Consumption / Consumo neumático	Machine Dimensions / Dimensiones de la máquina	Weight / Peso	Function / Función
DS/SCORPION-180S	Min: 90x110mm Max: 180x260mm	1200ml	40-60ppm	6.5kw	200 NL/min	L: 5550mm W: 1100mm H: 1400mm	2000Kg	Auto Stand Pouch (Doypack), Shape, Hanging Hole / Pouch auto estable (Doypack), Bolsa con forma, Agujero para colgar
DS/SCORPION-180SZ	Min: 90x110mm Max: 180x260mm	1200ml	40-60ppm	8kw	200 NL/min	L: 6080mm W: 1100mm H: 1400mm	2300Kg	Auto Stand Pouch (Doypack), Shape, Hanging Hole, Zipper / Pouch auto estable (Doypack), Bolsa con forma, Agujero para colgar, Cierre Hermético Zipper.
DS/SCORPION-180SC	Min: 90x110mm Max: 160x260mm	1000ml	40-60ppm	8kw	250NL/min	L: 5550mm W: 1100mm H: 1400mm	2200Kg	Auto Stand Pouch (Doypack), Shape, Hanging Hole, Top Spout / Pouch auto estable (Doypack), Bolsa con forma, Agujero para colgar, Spout superior
DS/SCORPION-180SX(B)	Min: 110x210mm Max: 180x260mm	1200ml	40-60ppm	9kw	250 NL/min	L: 6970mm W: 1100mm H: 1400mm	2500Kg	Auto Stand Pouch (Doypack), Shape, Hanging Hole, Corner Spout / Pouch auto estable (Doypack), Bolsa con forma, Agujero para colgar, Spout en esquina



# ECCOPAC SCORPION

## S/SCORPION FLAT POUCH SERIES

SERIE DE ENVASADORAS SACHET S/SCORPION

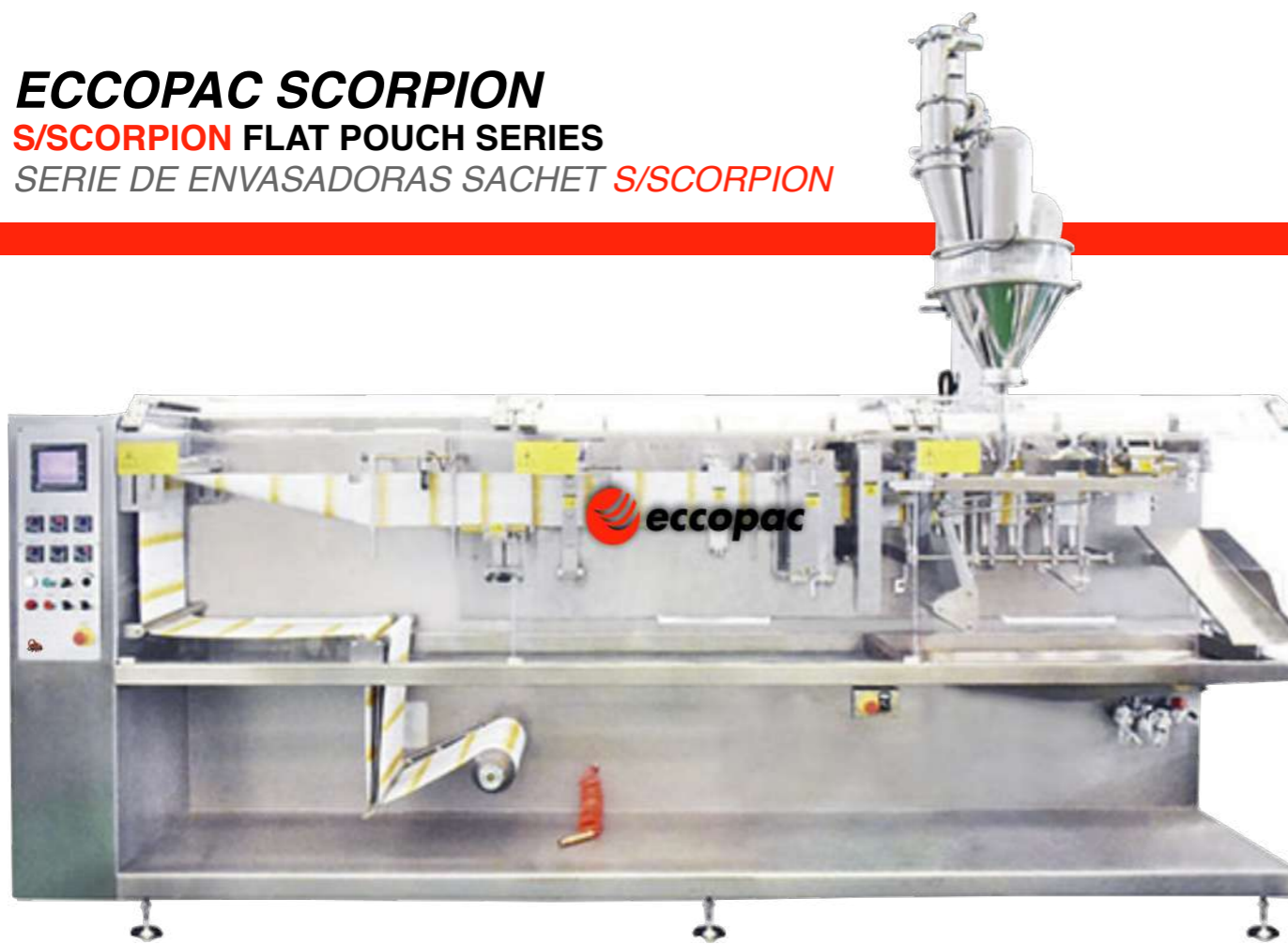

### S/SCORPION-180Z PRODUCTION FLOW:

1.Zipper Release 2.Film Unwind 3.Bag Forming 4.Zipper Guide 5.Film Guide 6.Photocell 7.Horizontal Zipper Seal 8.Vertical Zipper Seal I 9.Bottom Seal 10.Vertical Seal 11.Tear Notch 12.Servo Advance 13.Cutting 14.Pouch Catching 15.Pouch Opening 16.Filling I 17.Filling II 18.Top Seal 19.Finished Product 20.Outlet / 1. Desbobinador de zipper. 2. Desbobinador de film. 3. Formador de bolsa. 4. Guía de zipper. 5. Guía de film. 6. Sensor de fotocélula. 7. Sello horizontal del Zipper. 8. Sello vertical del zipper I. 9. Sello inferior. 10. Sello vertical. 11. Mueza abrefácil. 12. Tracción por servo. 13. Cuchilla. 14. Sujetador de sobre. 15. Abertura de sobre. 16. Llenado I. 17. Llenado II. 18. Sello superior. 19. Producto final.

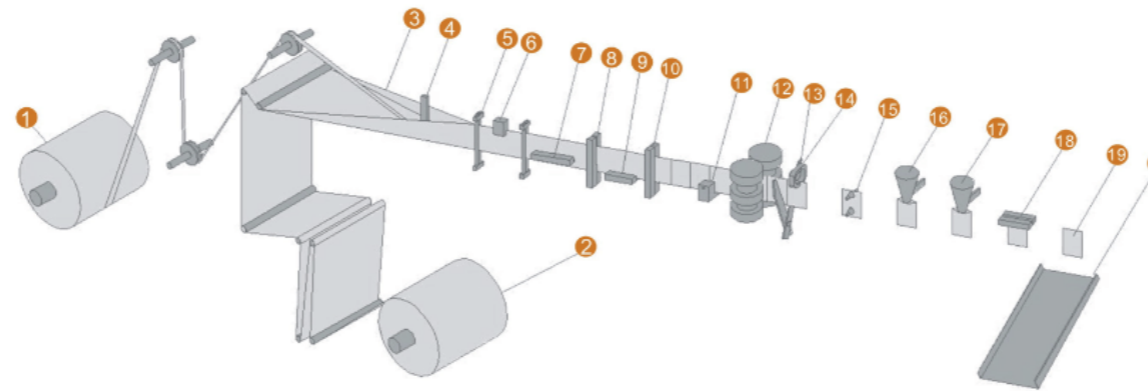

### INDEPENDENT SEALING DEVICE

- Independent pouch making, no products on seal. / Confección de sobres independientes. Si no hay sobre, no sella.
- Higher seal strength, less leakage. / Mayor fuerza de sellado, menor probabilidad de goteo.
- Better pouch appearance. / Mejor acabado final en sobres.



### DUPLEX FILLING STATION

- Reduce filling time by half. / Reduce el tiempo de llenado a la mitad.
- Improved filling accuracy. / Precisión de llenado mejorada.
- Can fill 2 products simultaneously. / Puede llenar bolsas de dos en dos.



### LINEAR GUIDE WALKING BEAM

- Faster working speed. / Mayor velocidad de trabajo.
- Longer operational lifespan. / Mayor vida útil operativa.

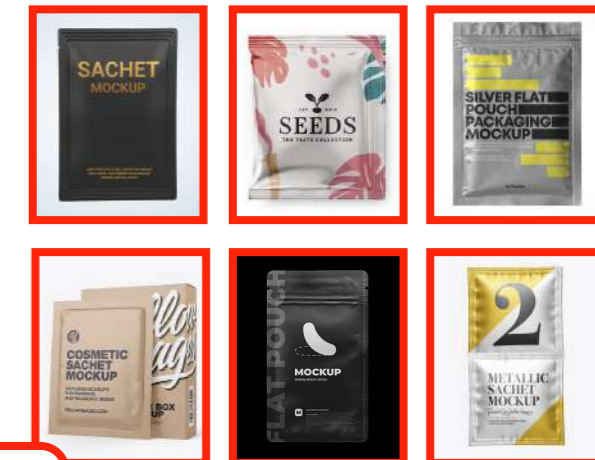

Model / modelo	Pouch Size / Dimensiones del pouch	Filling Capacity / Volumen de llenado	Packaging Capacity / Capacidad de Envasado	Power / Potencia	Air Consumption / Consumo neumático	Machine Dimensions / Dimensiones de la máquina	Weight / Peso	Function / Función
S/SCORPION-180	Min: 50x80mm Max: 180x225mm	400ml	40-80ppm	4.5kw	200 NL/min	L: 3500mm W: 970mm H: 1500mm	1160Kg	3 side seal, 4 side seal / sobre de 3 sellos, sobre de 4 sellos.
S/SCORPION-180T	Min: 50x80mm Max: 90x180mm	100ml	100-160ppm	4.5kw	200 NL/min	L: 3500mm W: 970mm H: 1500mm	1160Kg	3 side seal, 4 side seal, Twin link / sobre de 3 sellos, sobre de 4 sellos, tira de sobres.
S/SCORPION-180Z	Min: 50x80mm Max: 180x250mm	400ml	40-80ppm	5.5kw	200NL/min	L: 4660mm W: 970mm H: 1500mm	1160Kg	Flat pouch, shape, hanging hole, zipper / Sobre plano, sobre con forma personalizada, sobre con perforación colgante, sello hermético zipper.
S/SCORPION-180C	Min: 50x80mm Max: 180x225mm	400ml	40-80ppm	5.5kw	250 NL/min	L: 3810mm W: 970mm H: 1500mm	1270Kg	Flat pouch, shape, spout / Sobre plano, sobre con forma personalizada, sobre con boquilla dosificadora.



**eccopac**

# ECCOPAC SCORPION

## S/SCORPION FLAT POUCH SERIES

### SERIE DE ENVASADORAS SACHET S/SCORPION



#### S/SCORPION-180DS PRODUCTION FLOW:

1. Film Unwind 2. Pouch forming. 3. film guide. 4. Bottom seal. 5. Vertical Seal. 6. Tear Notch. 7. Photocell. 8. Duplex cutting. 9. Duplex pouch catching. 10. Advance. 11. Pouch opening. 12. Filling. 13. Vibrator. 14. Spout Adding. 15. Spout Inserting. 16. Finiched product. 17. Output / 1. Desbobinador de film. 2. Formador de sobres. 3. Guía de film. 4. Sello inferior. 5. Sello vertical. 6. Mueza abrefácil. 7. Sensor de fotocélula. 8. Doble cuchilla de corte. 9. Doble llevador de sobres. 10. Arrastre. 11. Abertura de sobre. 12. Estación de llenado. 13. Dosificador de boquillas por vibración. 14. Colocador de boquilla. 15. Selo de boquilla. 16. Producto final. 17. Tobogán de salida.

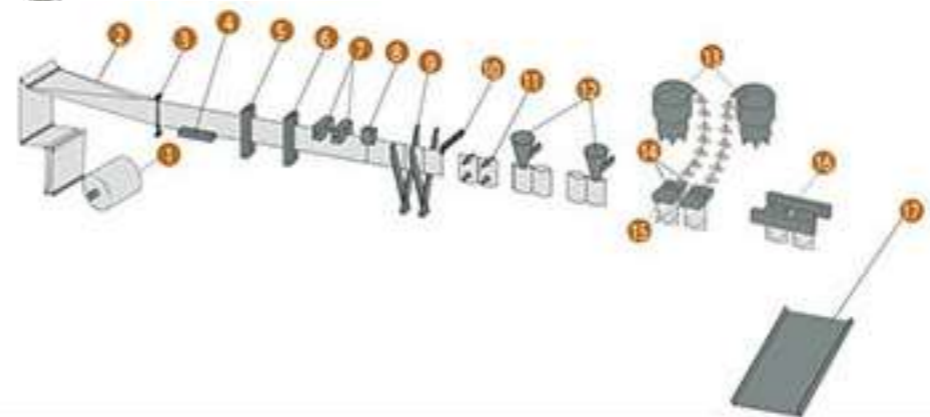

#### DUPLEX OUTPUT MACHINE

- 100-160 bpm output. / Salida de 100-160 bpm.
- Best option for limited space but high capacity need. / La mejor opción para espacios limitados y alta capacidad.



#### DUPLEX SPOUT FUNCTION

- Even spout seal with good appearance. / Sello de boquilla de buena apariencia.
- High spout seal strength, no leakage. / Sello de boquilla de alta calidad. Sin posibilidad de goteo.



#### DUPLEX SCISSOR STRUCTURE

- Stable operation, easy adjustment. / operación estable, fácil de calibrar.
- 2 pouches at the same time, double productivity. / 2 sobres al mismo tiempo, duplica la productividad.



Model / modelo	Pouch Size / Dimensiones del pouch	Filling Capacity / Volumen de llenado	Packaging Capacity / Capacidad de Envasado	Power / Potencia	Air Consumption / Consumo neumático	Machine Dimensions / Dimensiones de la máquina	Weight / Peso	Function / Función
S/SCORPION-180D	Min: 50x80mm Max: 90x180mm	100ml	120-160ppm	4.5kw	200 NL/min	L: 3500mm W: 970mm H: 1500mm	1500Kg	3 side seal, 4 side seal / sobre de 3 sellos, sobre de 4 sellos.
S/SCORPION-180DC	Min: 50x80mm Max: 90x180mm	100ml	100-160ppm	4.5kw	400 NL/min	L: 3850mm W: 970mm H: 1500mm	1800Kg	Flat pouch, shape, spout / Sobre plano, sobre con forma personalizada, sobre con boquilla dosificadora.

