

INTEGRA COMPACT LINE

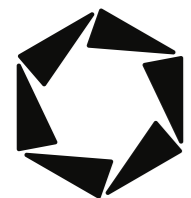

INTEGRA COMPACT PACKING MACHINE



ECCOPAC INTEGRA

COMPACT VERTICAL MULTIHEAD WEIGHER PACKING MACHINE

ENVASADORA VERTICAL COMPACTA CON DOSIFICADOR DE MULTICABEZAL

ECCOPAC INTEGRA/1040-1440

Main Features // Características Principales

The Integra/1040 and Integra/1440 packaging line is a series of compact machinery that can automatically package products and save space. These machines can form bags from reels with a maximum width of 400 mm. Depending on the model of the machine, it can have a multihead dispenser integrated into the packaging system with 10 or 12 heads, which can vary by volume from 0.5L, 0.8L and 1L. These pieces of equipment guarantee precision in each dose. // La línea de envasadoras Integra/1040 e Integra/1440 es una serie de maquinaria compacta que puede envasar productos de manera automática y ahorrando espacio. Estas máquinas pueden formar la bolsas desde bobinas de ancho máximo de 400mm. Según el modelo de la máquina, puede contar con un dosificador multicabezal integrado al sistema de envasado de 10 o 12 cabezales, que pueden variar por su volumen de capacidad de 0.5L, 0.8L y 1L. Estos parte del equipo garantiza una precisión en cada dosis.

Appication // Aplicación

The compact machines are mainly used to pack quantifiable or granulated products by weight, thanks to their high precision. It is normally used to package products such as beans, candies, snacks, puffed foods, seeds, dried fruits, pet food, hardware, etc. // Las máquinas compactas son utilizadas principalmente para envasar productos cuantificables o granulados por peso, gracias a su alta precisión. Normalmete se utiliza para envasar productos como menestras, caramelos, snacks, alimentos inflados, semillas, frutas secas, alimentos para mascotas, artículos de ferretería, etc.



INTEGRA/1040-08



INTEGRA/1440-05



INTEGRA/1040-10



eccopac

ECCOPAC INTEGRA/1040-1440

INTEGRA/1040-08

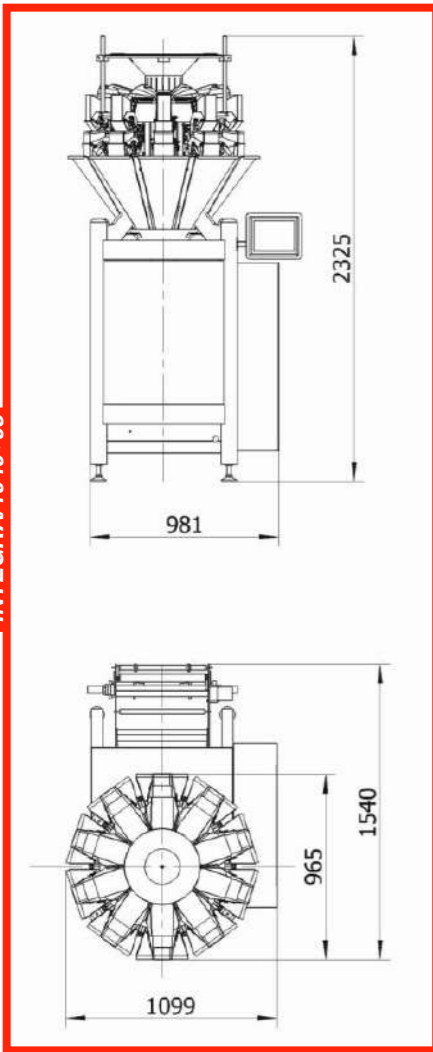

INTEGRA/1440-05

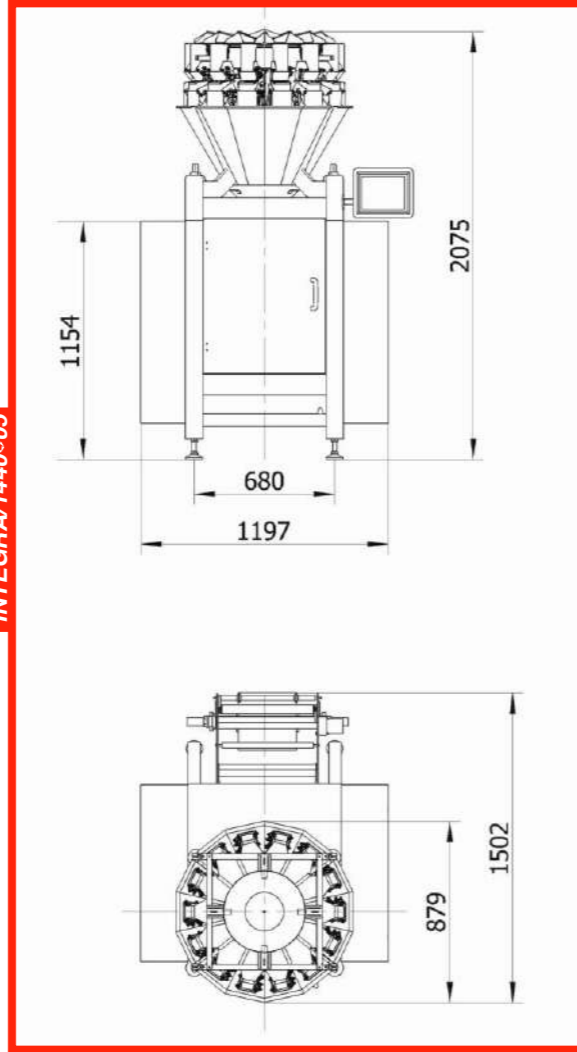

INTEGRA/1040-10

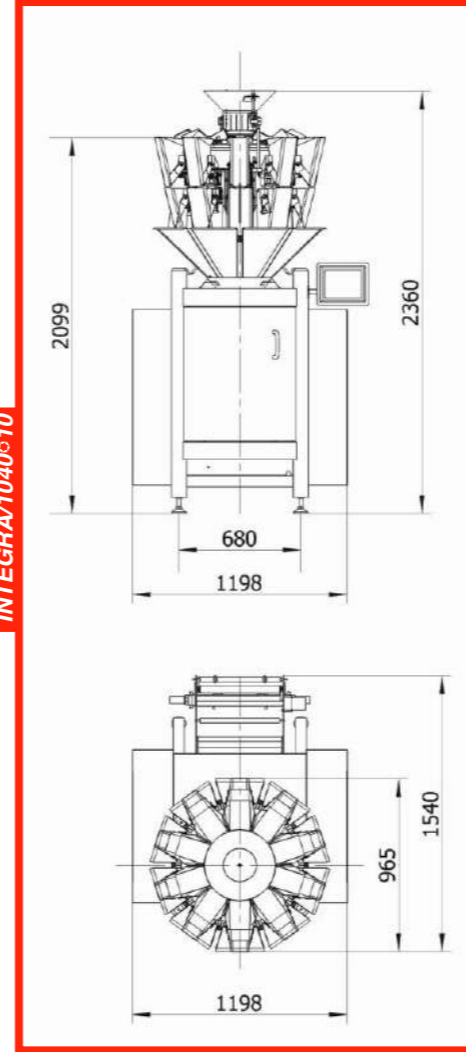

MODEL // MODELO	INTEGRA/1040-08	INTEGRA/1440-05	INTEGRA/1040-10
DISPLAY // PANTALLA	10.4 inch touch screen	10.4 inch touch screen	10.4 inch touch screen
QTY. WEIGH HEAD // NÚMERO DE BALANZAS	10	14	10
WEIGH BUCKET VOLUME // VOLUMEN DE BUCKET	0.8L	0.5L	1L
HOPPER MATERIAL // MATERIAL DE TOLVA	304 stainless steel	304 stainless steel	304 stainless steel
SINGLE WEIGHING RANGE // RANGO DE PESO POR TOLVA	10-500g	10-500g	10-1,000g
MAX WEIGHT // PESO MÁXIMO	1,000g	1,000g	1,000g
WEIGHING ACCURACY // PRECISIÓN DE PESADO	±0.3-1.5g	±0.3-1.5g	±0.3-1.5g
MAX WIDTH OF ROLL FILM // ANCHO MÁXIMO DE FILM	400mm	400mm	400mm
BAG WIDTH // ANCHO DE BOLSA	60-190mm	60-190mm	60-190mm
BAG LENGTH // LARGO DE BOLSA	50-230mm	50-230mm	50-230mm
PACKING FILM MATERIALS // MATERIAL DE FILM	Complex film	Complex film	Complex film
FILM DRIVE POWER // TRACCIÓN DE FILM	Servomotor	Servomotor	Servomotor
END SEAL POWER // SELLO HORIZONTAL	Cylinder	Servomotor	Cylinder
AIR CONSUPTION // CONSUMO NEUMÁTICO	0.3m³/min, 0.6MPa	0.2m³/min, 0.6MPa	0.3m³/min, 0.6MPa
MAX PACKING SPEED // VELOCIDAD MÁXIMA DE ENVASADO	60 bags/min	90 bags/min	60 bags/min
POWER // POTENCIA	4Kw	4Kw	4Kw
VOLTAGE / FRECUANCY // SUMINISTRO ELÉCTRICO	220V 50/60Hz	220V 50/60Hz	220V 50/60Hz
NW / GW // PESO NETO / BRUTO	500Kg / 700Kg	540Kg / 740Kg	550Kg / 750Kg
PACKAGE SIZE // DIMENSION	1556*1366*2078mm	1556*1366*2078mm	1530*1300*2300mm



eccopac

ECCOPAC INTEGRA

COMPACT VERTICAL MULTIHEAD WEIGHER PACKING MACHINE

ENVASADORA VERTICAL COMPACTA CON DOSIFICADOR DE MULTICABEZAL

Main Features // Características Principales

The Integra/1250 and Integra/1450 packaging line is a series of compact machinery that can automatically package products and save space. These machines can form bags from reels with a maximum width of 500 mm. Depending on the model of the machine, it can have a multihead dispenser integrated into the packaging system with 12 or 14 heads, which can vary by volume from 1L and 0.8L. These pieces of equipment guarantee precision in each dose. // *La línea de envasadoras Integra/1250 e Integra/1450 son una serie de maquinaria compacta que puede envasar productos de manera automática y ahorrando espacio. Estas máquinas pueden formar la bolsas desde bobinas de ancho máximo de 500mm. Según el modelo de la máquina, puede contar con un dosificador multicabezal integrado al sistema de envasado de 12 y 14 cabezales, que pueden variar por su volumen de capacidad de 1Ly 0.8L. Estos parte del equipo garantiza una precisión en cada dosis.*

Application // Aplicación

The compact machines are mainly used to pack quantifiable or granulated products by weight, thanks to their high precision. It is normally used to package products such as beans, candies, snacks, puffed foods, seeds, dried fruits, pet food, hardware, etc. // *Las máquinas compactas son utilizadas principalmente para envasar productos cuantificables o granulados por peso, gracias a su alta precisión. Normalmente se utiliza para envasar productos como menestras, caramelos, snacks, alimentos inflados, semillas, frutas secas, alimentos para mascotas, artículos de ferretería, etc.*

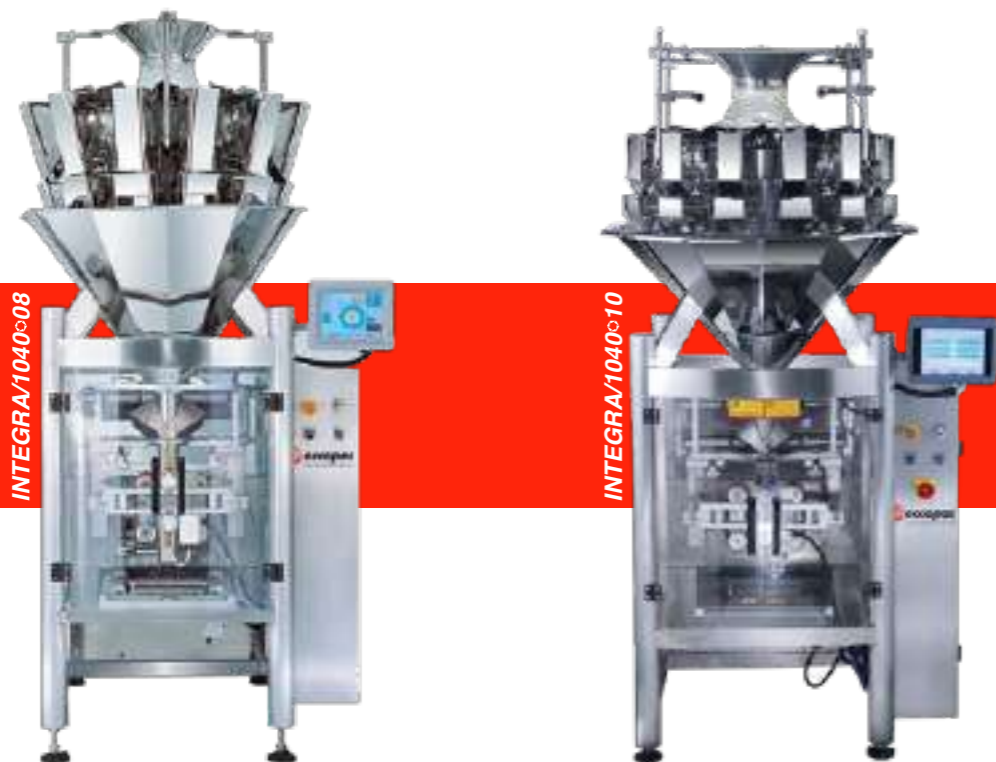

eccopac

ECCOPAC INTEGRA/1250-1450

INTEGRA/1250-10

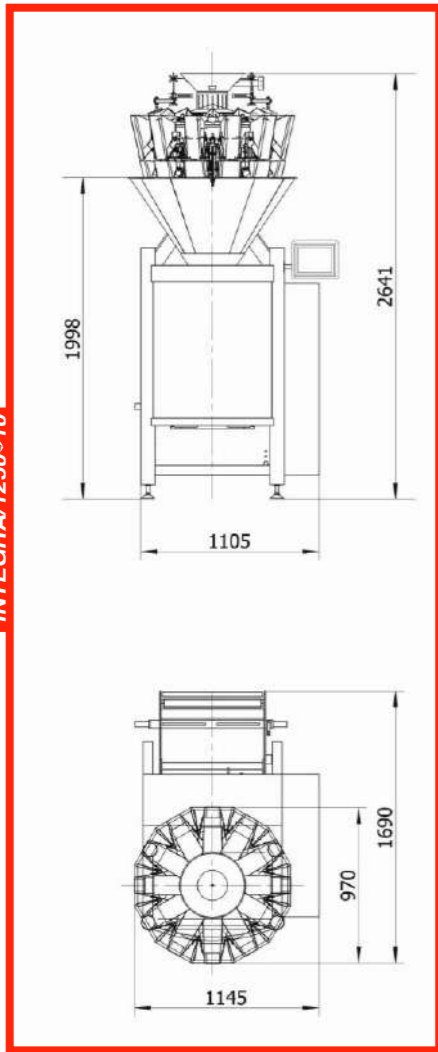

INTEGRA/1450-08

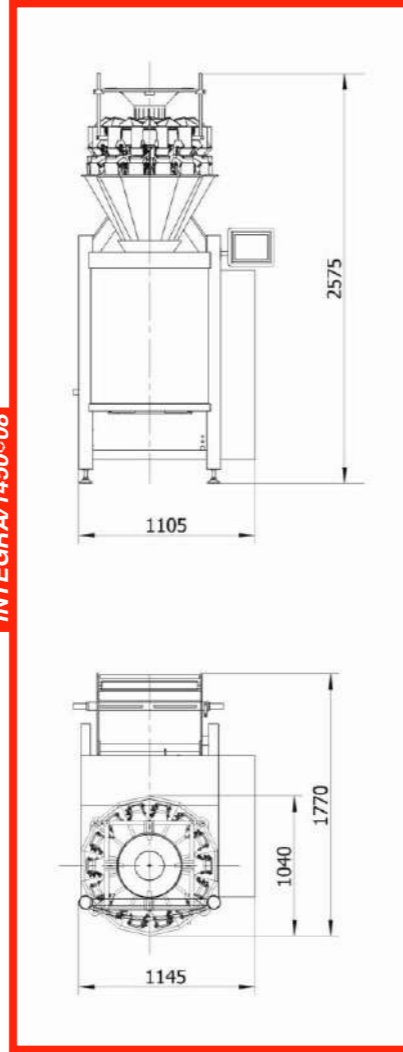

MODEL // MODELO	INTEGRA/1250-10	INTEGRA/1450-08
DISPLAY // PANTALLA	10.4 inch touch screen	10.4 inch touch screen
QTY. WEIGH HEAD // NÚMERO DE BALANZAS	12	14
WEIGH BUCKET VOLUME // VOLUMEN DE BUCKET	1L	0.8L
HOPPER MATERIAL // MATERIAL DE TOLVA	304 stainless steel	304 stainless steel
SINGLE WEIGHING RANGE // RANGO DE PESO POR TOLVA	10-1,000g	10-1,000g
MAX WEIGHT // PESO MAXIMO	1,000g	1,000g
WEIGHING ACCURACY // PRECISIÓN DE PESADO	±0.5-1.5g	±0.5-1.5g
MAX WIDTH OF ROLL FILM // ANCHO MÁXIMO DE FILM	500mm	500mm
BAG WIDTH // ANCHO DE BOLSA	60-240mm	60-240mm
BAG LENGTH // LARGO DE BOLSA	50-290mm	50-290mm
PACKING FILM MATERIALS // MATERIAL DE FILM	Complex film	Complex film
FILM DRIVE POWER // TRACCIÓN DE FILM	Servomotor	Servomotor
END SEAL POWER // SELLO HORIZONTAL	Servomotor	Servomotor
AIR CONSUPTION // CONSUMO NEUMÁTICO	0.3m³/min, 0.6MPa	0.3m³/min, 0.6MPa
MAX PACKING SPEED // VELOCIDAD MÁXIMA DE ENVASADO	100 bags/min	100 bags/min
POWER // POTENCIA	4Kw	4Kw
VOLTAGE / FREQUANCY // SUMINISTRO ELÉCTRICO	220V 50/60Hz	220V 50/60Hz
NW / GW // PESO NETO / BRUTO	650Kg / 850Kg	650Kg / 850Kg
PACKAGE SIZE // DIMENSION	1630*1320*2600mm	1630*1320*2600mm



eccopac

ECCOPAC INTEGRA

COMPACT VERTICAL PACKING MACHINE

ENVASADORA VERTICAL COMPACTA

ECCOPAC INTEGRA/300



Main Features // Características Principales

- Compact Design and saves space. // *Diseño compacto y ahorra espacio.*
- Controlled by PLC, touch screen for easy operation. // *Controlado por un PLC y una pantalla táctil, para fácil operación.*
- Quickly and easily change former. // *Cambio de hombro formador fácil y rápido.*
- Intermittent motion, the max. bag width can reach 300mm. // *Movimiento intermitente de sellado, la bolsa más ancha puede ser de 300mm.*
- For all heat-sealable packaging film and PE films. // *Para todos los films termo-sellables incluyendo PE.*
- For pillow or gusseted bag with a volume up to 7.5L. // *Para formar bolsas tipo almohada o con fuelle de fondo plano con un volumen de hasta 7.5L.*
- It can be connected with the combination scale, linear scale, measuring cup, suger filler or other measuring equipment to make a packing line. // *Se puede conectar con un dosificador de balanzas multicabezal, balanzas lineal, la taza telescópica volumétrica, dosificador de azúcar u otro equipo de dosificación para formar una línea de envasado automática.*

Appication // Aplicación

This series of vertical packing machine can form, fill and seal any product depending on the filling machine. It is suitable for packing wet noodle, salad, chicken pieces and other food or non-food products. // *Esta serie de máquinas emparadoras verticales puede formar, llenar y sellar cualquier producto dependiendo de la máquina llenadora. Es adecuado para envasar fideos húmedos, ensaladas, piezas de pollo y otros productos alimenticios o no alimenticios.*



MODEL // MODELO	INTEGRA/300S	INTEGRA/300D
CONSTRUCTION // CONSTRUCCIÓN	Stainless Steel	Stainless Steel
MAX WIDTH OF ROLL FILM // ANCHO MÁXIMO DE FILM	620mm	620mm
BAG WIDTH // ANCHO DE BOLSA	70-300mm	70-300mm
BAG LENGTH // LARGO DE BOLSA	100-300mm	100-300mm
BAG STYLE // TIPO DE BOLSA	Pillow bag , Gusset bag	Pillow bag , Gusset bag
FILM THICKNESS // ESPESOR DE FILM	0.04-0.12mm	0.04-0.12mm
AIR CONSUPTION // CONSUMO NEUMATICO	0.6m³/min, 0.6MPa	0.4m³/min, 0.6MPa
MAX PACKING SPEED // VELOCIDAD MÁXIMA DE ENVASADO	60 bags/min	90 bags/min
POWER // POTENCIA	3KW	3KW
VOLTAGE / FREQUANCY // SUMINISTRO ELÉCTRICO	220V 50Hz	220V 50Hz
OVERALL DIMENSIONS // DIMENSION	1450x1180x1300mm	1450x1180x1300mm



eccopac

ECCOPAC INTEGRA

COMPACT VERTICAL AUGER FILLER PACKING MACHINE

ENVASADORA VERTICAL COMPACTA CON DOSIFICADOR DE TORNILLO

Main Features // Características Principales

- Full stainless steel structure with combined type transparent hopper, which could be washed easily without tools. // Estructura construida en acero inoxidable con cubierta transparente en la tolva del dosificador, puede ser limpiada fácilmente sin herramientas.
- Servo motor and driver control auger. // Tornillo comandado por servomotor y driver.
- 10 sets of products information can be pre-stored for easy operation. // Se puede almacenar la información de envasado de hasta 10 productos.
- By changing the auger parts, it's suitable for material from super thin powder to granule with different ranges. // Se puede envasar polvos muy finos cambiando algunas partes del dosificador de tornillo.

Appication // Aplicación

The machine is used for dosifying, filling and packing the powder, flour, solid beverage, cocoa powder, chicken powder, granulated sugar, glucose, food additives, feed, pharmaceutical raw materials, dye, flavor spices, etc. // La máquina es usada para dosificar, llenar y envasar polvos, harinas, bebidas en polvo, cocoa en polvo, caldo de pollo, saborizantes, azúcar granulada, glucosa, aditivos para alimentos, fármacos, sabores, especias y otros productos en polvo.



MODEL // MODELO	INTEGRA/A
CONSTRUCTION // CONSTRUCCIÓN	Stainless Steel
HOPPER // TOLVA	25-50L
FILLING RANGE // RANGO DE LLENADO	10-2000g
ACCURACY // PRECISION	1%±2%
MAX WIDTH OF ROLL FILM // ANCHO MAXIMO DE FILM	620mm
BAG WIDTH // ANCHO DE BOLSA	70-300mm
BAG LENGTH // LARGO DE BOLSA	100-300mm
BAG STYLE // TIPO DE BOLSA	Pillow bag , Gusset bag
FILM THICKNESS // ESPESOR DE FILM	0.04-0.12mm
AIR CONSUPTION // CONSUMO NEUMÁTICO	0.6m³/min, 0.6MPa
MAX PACKING SPEED // VELOCIDAD MÁXIMA DE ENVASADO	60 bags/min
POWER // POTENCIA	4KW
VOLTAGE / FREQUANCY // SUMINISTRO ELÉCTRICO	220V 50Hz



ECCOPAC INTEGRA COMPLETE PACKING LINE

**COMPACT MACHINE + Z BUCKET
ELEVATOR + TAKE AWAY + METAL
DETECTOR + CHECK WEIGHER**



**VERTICAL PACKING MACHINE
+ MULTIHEAD WEIGHER + PLATFORM**

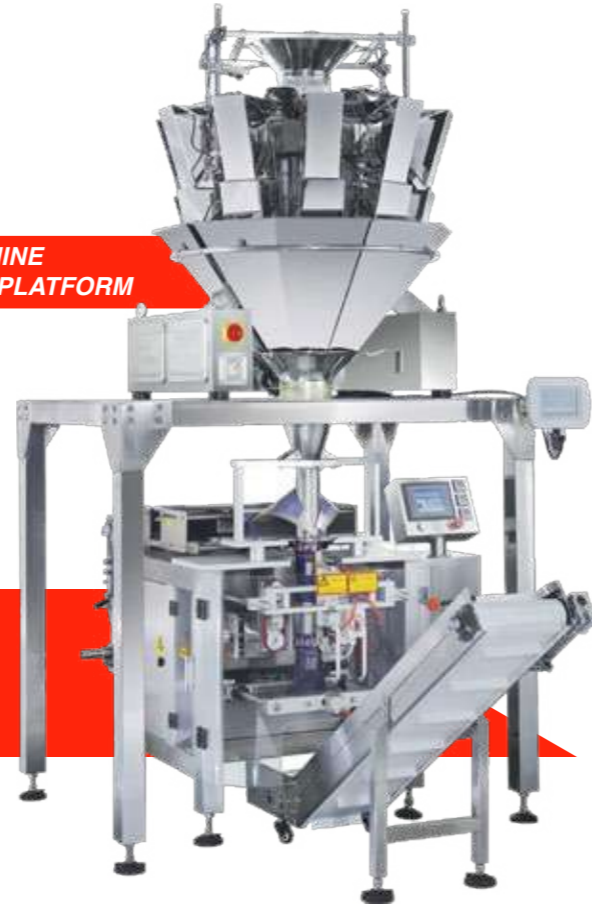

**VERTICAL PCOMPACT PACKING MACHINE + MULTIHEAD WEIGHER
+ VIBRATOR FEEDER + ACCLIVITOUS CONVEYOR + PLATFORM**



ECCOPAC INTEGRA - INTEGRATED OPTIONS



VERTICAL COMPACT PACKING MACHINE WITH PARCEL DELIVERY DEVICE



VERTICAL COMPACT PACKING MACHINE WITH METAL DETECTOR RING

DISPLAY // PANTALLA	Touch screen	
MODEL // MODELO	INTEGRA + MD	
DETECTING TUNNEL // TUNEL DETECTOR	Ø100mm	Other sizes could be customized.
SENSITIVITY FE // SENSIBILIDAD FE	Ø0.6mm	
SENSITIVITY SUS // SENSIBILIDAD SUS	Ø1.8mm	
ACTUAL SENSITIVITY // SENSITIVIDAD ACTUAL	Depends on product effect of its own.	
OUTMUO MODE // FORMA DE RECHAZO	Sound and light alarm, T-pusher or belt stop (optional)	

